

CDP-G

Dynamic power controller with demand management



Description

CDP-G is a dynamic power controller which modifies the MPPT (Maximum Power Point Tracker) of the inverters in order to regulate the PV generation according to the energy consumption of the user and besides, it allows using the excesses of PV production. **CDP** product range regulates the PV production according to the power consumption in any self-consumption PV system to control the power that you are feeding into the grid.

CDP-G incorporates all the features of the **CDP-0** and moreover it has 3 relay outputs to connect loads and to use the excess of PV production. By connecting non-critical loads during sunny hours in the day it allows to have a lower level of grid dependence and a reduction of energy costs.

By programming a value of power consumption and a priority level to each output, **CDP-G** is able to calculate and to connect automatically each load in the right moment depending on the excess of PV production. Moreover, **CDP-G** allows to assign a percentage of grid contribution to these loads in order to improve the performance of the PV system.

Some of the main features of the **CDP-G** are:

- Management of 3 loads
- Usage of PV production excess
- Possibility to manage the main solar inverters in the market and many solar inverters* by system
- Web monitoring (smart-phones, tablets or PC)
- Data logger and file downloading (.csv) through any web browser
- Web configuration of many parameters
- Display with on-line data of PV production, user consumption and grid consumption
- MODBUS/TCP communications to allow SCADA integrations.

Applications

- Self-consumption PV systems (with/without) grid injection with usage of PV production excess
- Remote monitoring systems and energy balance trending (with or without grid injection)
- Management of heat pumps (aerothermal or geothermal)
- Water heating with the use of thermoaccumulators (swimming pools, homes)
- Water pumping and irrigation applications
- Production of compressed air.

Technical features

Power supply circuit	Rated voltage	230 Vac (80%...115%)
	Frequency	50...60 Hz
	Consumption	6 VA / 6 W
	Rated voltage	12 Vdc
Voltage measurement circuit	Measurement margin	10...300 Vac
	Frequency	50...60 Hz
Current measurement circuit	Nominal current	.../250 mA
	Maximum current	.../300 mA
Accuracy class	Power	0.5%
	Energy	1.0%
Relay outputs	Number	4
	Type	Potential-free
	Maximum operating current	6 A
Communications	User interface	Ethernet
	Communication with the inverter	RS-232, RS-485, RS-422
	Communication with other units	RS-485
Mechanical features	Dimensions	6 DIN modules
	Material	UL94 – V0 self-extinguishing plastic
	Weight	250 gr
	Operating temperature	-25 °C...+70 °C
Environmental conditions	Relative humidity	95% without condensation
	Standards	IEC 61010-1:2010, IEC 61000-6-2:2005, and IEC 61000-6-4:2011

References

Type	Code	Description
CDP-G	E52001	Dynamic Power Controller with demand management

Dimensions

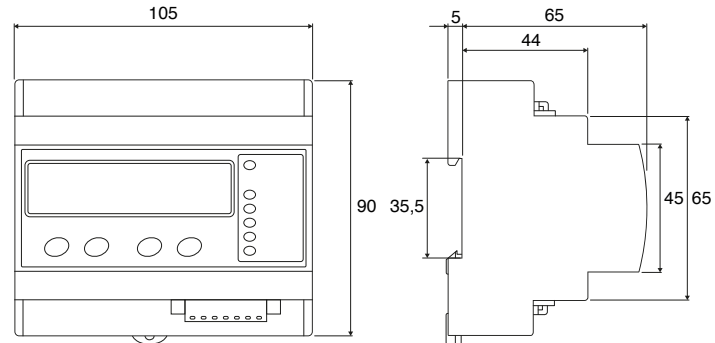

Connections

