

CDP-DUO

Dynamic power controller dual configuration



Description

CDP-DUO is the evolution of dynamic power controllers designed to control hybrid installations (powered by two alternative sources of energy). The unit measures the consumption of the user at all times, thanks to its dual configuration, regulating the inverters to adapt the solar energy generation to the type of network and/or generator installed.

The main advantage of **CDP-DUO** is that it can automatically switch the network configuration, according to the type of network. If it is combined with FRONIUS inverters, the user can also perform power factor correction tasks, thanks to its new built-in *driver*.

- Some of the main features of **CDP-DUO**:
- Identification of the type of network and adaptation of the regulation, according to the type of network.
- Power factor correction of the installation*
- Monitoring via web (smartphone, tablet or PC)
- Datalogger and downloading of a .csv file with historical consumption data via web
- Many different regulation options via web
- Screen with consumption, PV production and network/group consumption information
- Optional use of power analyzers to increase the amount of information provided
- Modbus/TCP communications for integration in SCADA

* Only with Fronius inverters

** Check the current list of inverters managed on the web site.

Applications

- Hybrid self-consumption photovoltaic energy installations with injection control systems
- Photovoltaic energy installations with monitoring system
- Remote energy balance monitoring and recording system (with or without injection into the grid)

Technical features

Power supply circuit	Rated voltage (Tolerance)	230 Vac (80...115%)
	Frequency	50...60 Hz
	Consumption	6 VA
	Rated voltage	12 Vdc
Voltage measurement circuit	Consumption	6 W
	Measurement margin	10...300 Vac
Current measurement circuit	Frequency	50...60 Hz
	Nominal current	.../250 mA
Accuracy class	Maximum current	.../300 mA
	Power	0.5%
Relay outputs	Energy	1.0%
	Number	4
	Type	Potential-free
Communications	Maximum operation current	6 A
	User interface	Ethernet
	Communication with the inverter	RS-232, RS-485, RS-422
	Communication with other units	RS-485
Mechanical features	Dimensions	3 DIN modules
	Material	UL94 - V0 self-extinguishing plastic
	Weight	250 g
Environmental conditions	Working temperature	-25...+70 °C
	Relative humidity	95% without condensation
Standards	Safety requirements for electrical equipment for measurement and control IEC 61010-1:2010 , electromagnetic compatibility IEC 61000-6-2:2005 , and IEC 61000-6-4:2011	

CDP-DUO

Dynamic power controller with dual configuration

References

Type	Code	Description
CDP-DUO	E52001	Dynamic power controller with dual configuration

Dimensions

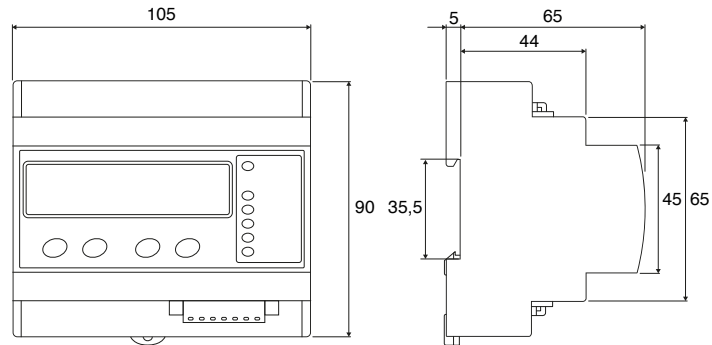

Web display

12:24:16 2017/01/09	13:33:27 2017/01/09
2500 W 100%	2500 W 100%
485 W	1411 W
8082 W	21445 W
7597 W	19604 W
Download	Download
Relay 1 Relay 2 Relay 3 Disabled	Relay 1 Relay 2 Relay 3 Disabled

Connections

